

Product Dimension:

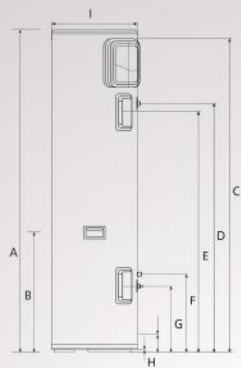

Split Unit:

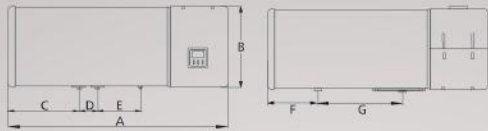
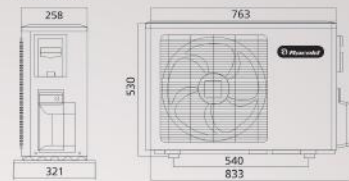

Split 150ltrs. / 200ltrs.

Model	A	B	C	D	E	F	G	H	I
150	1486	670	1429	1024	1004	414	364	17	495
200	1894	705	1841	1462	1409	460	390	17	510



The product comes with a 2 year warranty on inner tank & 2 year on the product, assuring a dependable service



An ISO 9001:2008 Certified Company

Frequently Asked Questions (FAQ's)

- Why should I use a Heat Pump Water Heater instead of Electrical Storage Water Heater?**
 - Heat Pump Water Heater can save more than 70% of electricity when compared to a normal Electric Water Heater. Electricity is used to run the compressor and not to heat the water.
- Where should I install a Heat Pump Water Heater?**
 - Heat Pump Water Heater can be installed in a bathroom, balcony, kitchen, storeroom, etc, virtually anywhere in the house without affecting the outlook of the building.
- What is the heat source of the Heat Pump Water Heater?**
 - It draws heat from air (atmosphere) so that the product continues to supply hot water in all weather conditions irrespective of the water heater location.



Ariston Thermo India Private Limited
2nd Floor, Eastern Wing, Nyati Unitree, Nagar Road,
Yerwada, Pune Maharashtra 411006
Board Line: 020 6740 9900

Ariston Thermo Spa, Viale Aristide Merloni 45, 60044,
Fabriano (AN) - Italy, +39 0732 6011
www.aristonthermo.com



India's largest provider of water heating solutions.



Racold India

**Lifetime Savings,
One Time Investment!**



Heat Pump Water Heaters



www.racold.com

Reborn Everyday With Hot Water

Racold is the largest provider of complete water heating solutions in India. We have served millions of consumers over the last 50 years and have, deservedly, been awarded the most trusted brand award, 2016.

We are constantly innovating to enhance our products and your experience with energy efficient water heating solutions. Our efforts have been awarded with the National Energy Conservation Award, a consecutive 7 times from 2010 to 2016, this is for BEE and MNRE Award for the Best Performed Manufacturer in 2012 and the Best Service and Dealer Network in India in 2013.

Why Heat Pump Water Heaters?

It uses 70% less electricity compared to conventional water heating solutions. It uses electricity only to move heat from one place to another instead of using it to generate heat. This results in 70% less electricity consumption.

70%
Energy Savings

- Heat pump water heaters have a COP (Co-efficient of performance) of 3.6, meaning that the energy produced in the form of hot water is 3.6 times more than that is consumed.
- By comparison, electric water heaters have a COP of less than 1, resulting in heat pump water heaters giving an annual saving of approx. Rs 9300/-



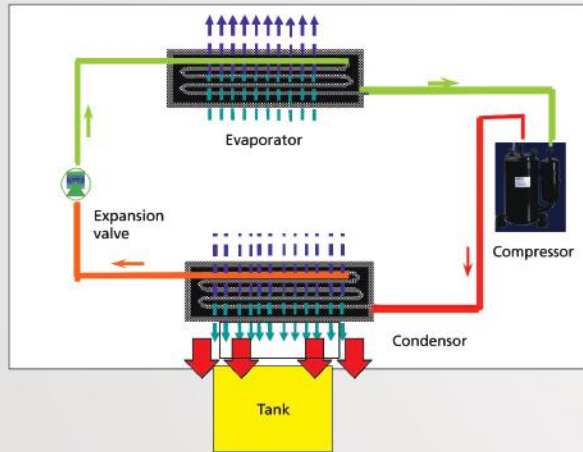



How Does It Work?



Thermodynamic Cycle

- External air is sucked inside the heat pump with the help of a fan
- Since the refrigerant in the evaporator is kept at a lower temperature than the surrounding atmosphere, it absorbs heat from the surroundings and evaporates
- The compressor compresses the gaseous refrigerant and raises the pressure and temperature of the refrigerant
- The heated refrigerant runs through the condenser coil wrapped around the storage tank, transferring the heat to the water stored there and it cools and condensates
- The refrigerant then passes through an expansion valve where the pressure and temperature is reduced further for the whole process to start again

Features:

 Isolated Safe Condenser: Designed according to European standards, this ensures safety and superior conduction of heat.	 Magnesium Anode: Protects your water heater and gives it a long life.
 High Efficiency Compressor: It ensures faster heat exchange, more hot water and increased savings.	 Quick Heating: In this option the Water Heater will work in both Heat Pump and Heating Element mode, giving instant hot water.
 Titanium Enameled Tank: A new technology which uses titanium enamelling for the inner container ensures greater corrosion resistance against hard water.	 Intelligent Controller: Temperature and the time when hot water is required can be easily set via smart digital.

Technical Specification

Sl. No.	Model	150 Ltrs.	200Ltrs.
1	Capacity (Ltrs)	150	200
2	Product Configuration	Split	
3	COP	3.6	
4	Noise level in dB (1 meter as per standard)	52	
5	Operating pressure (Bar)	8	
7	Heating element (kW)	1.8	
8	Refrigerant	R134a	
9	Tank net weight -without water (Kgs)	50	75
10	Product dimensions (mm)	495 x 1486	510 x 1894
12	Mains Electrical Connection (V/Hz)	(198-264)V/50Hz	
13	Anode	Mg	
14	Maximum temperature setting - HP Mode (°C)	55	
15	Maximum temperature setting with Electrical heating element (°C)	75	
16	Heating time (h:min) HP	2:20	3:20
17	Heating time (h:min) HP+HE	1:20	2:00
18	Power output (W)	2600	
19	Power input (W)	720	
20	Volume @ 40 degrees C (Ltrs.)	209	282

All these measuring values obtained with air temperature of 20%/ 59% humidity.

Comparative Analysis:

Parameters	Heat Pump water heater	Electric water heater
Operating cost (%)	28	100
Place of Installation	Any place	Any place
Source of Energy	2/3 from atmosphere (renewable energy) + 1/3 from electrical power	Electrical power
Heating Time*	2 hours (multiple heating cycles)	2 - 3hrs (multiple heating cycles)
Temperature of Hot water	55°C	60 to 70° C
Climatic constraints	None (Works throughout the year)	None (Works throughout the year)

*Capacity - 150 ltrs water